



CIMug Meeting – 10 June 2008
Västerås, Sweden
GID Tutorial

Business Process Automation



What is it and why is it important?

GID Tutorial – Västerås



Application Integration Challenges

- Our Goal: Applications are inherently capable of **interoperating** with other systems and performing **integrated** application functions in a cooperative and distributed manner.
- Getting data to/from applications is only the first step (interoperation).
- Getting applications to cooperate in a distributed manner (integration) means that they must be aware of and implement your **business process**.
- Your business process is the procedures, steps, and rules that you follow every day to accomplish a business objective.



Step 1: Start with a simple process

- Hypothetical existing business process start out simple

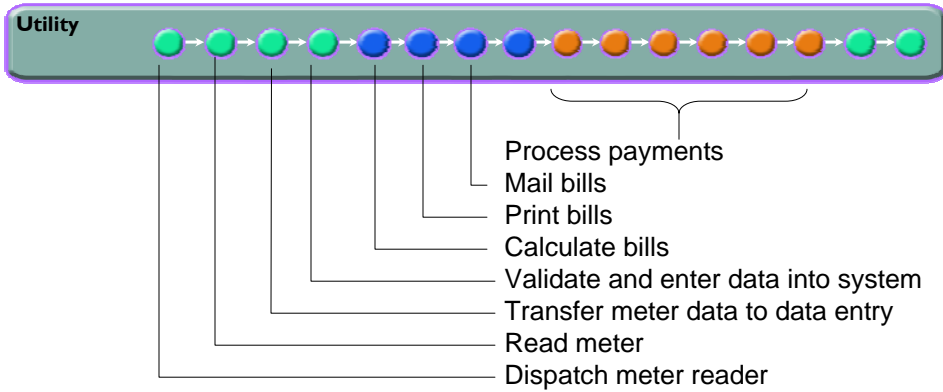

Integration for simple meter reading process

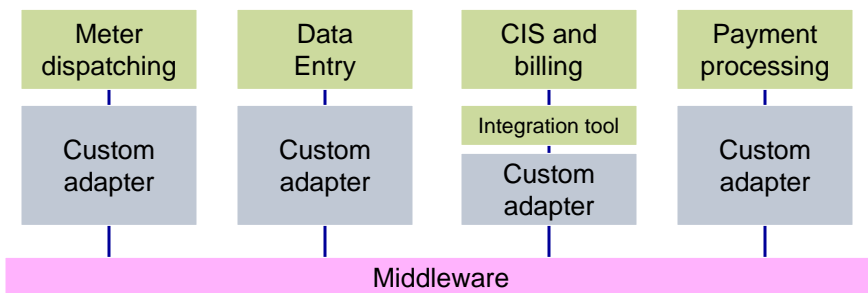

The inevitable happens: CHANGE

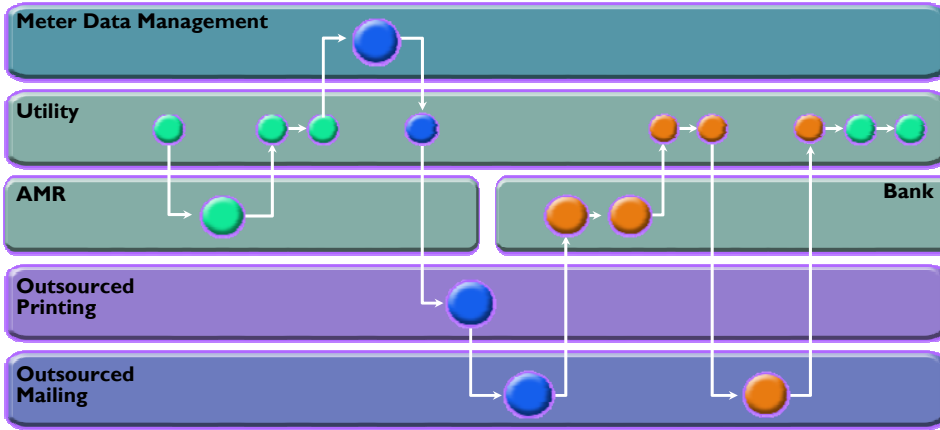

Impact of Change- rewrite, revise, re-everything

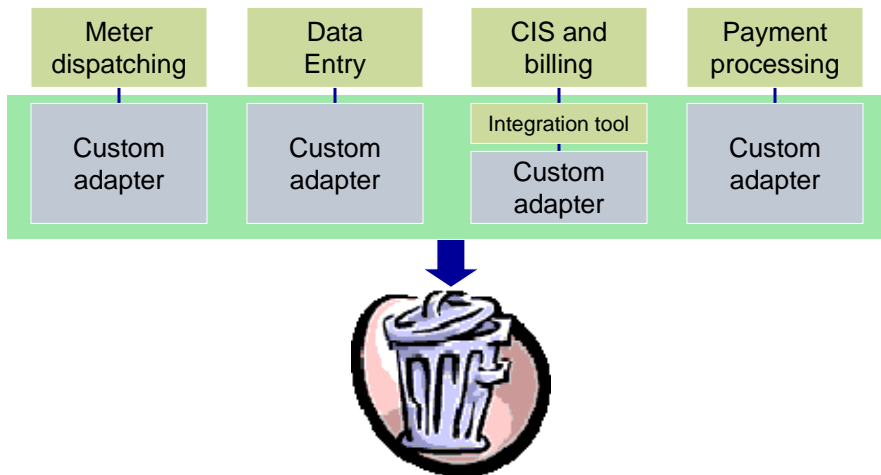

Why did it break?

- The logic of the business process is embedded in the application adapters
- When the process changes the adapters must change
 - Applications adapters become dependent on the rules and processes defined in the other adapters
- If the process changes too much, the entire system can be broken
- BUSINESS PROCESS **AUTOMATION** is needed

Model Driven Development Accelerates Results

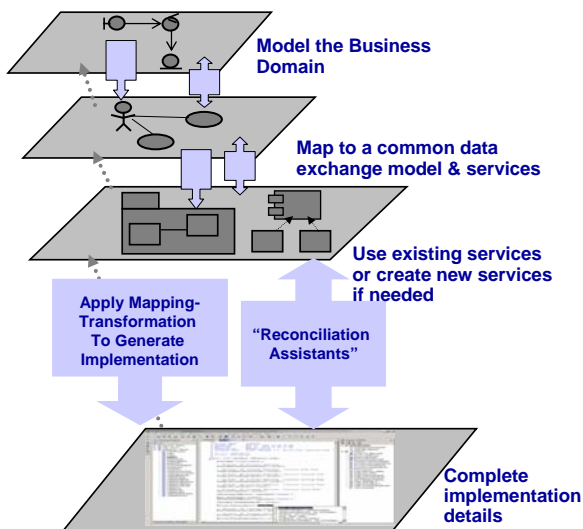

- Raise the level of communication
- Reduce complexity
 - Create and manage abstract representations
- Improve quality and time to value through automation
 - Seamless model integration reduces translation errors
- Manage change
 - Maintain traceability across artifacts

Remove the Business Logic from Adapters to Enable Model Driven Integration

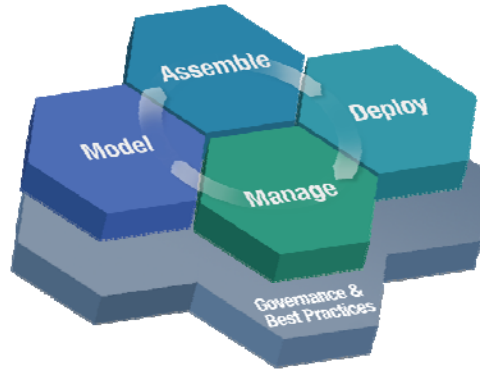

Modeling Business Logic

Case Name	Distribution	Success Status	Average Total Cost
Case 1	42%	Succeeded	\$96,571,333
Case 2	1%	Succeeded	\$137,199
Case 3	5%	Succeeded	\$106,161,333
Case 4	1%	Succeeded	\$96,893
Case 5	1%	Succeeded	\$134,931,333
Case 6	1%	Succeeded	\$121,215,667
Case 7	1%	Succeeded	\$115,761,333
Case 8	2%	Succeeded	\$102,964,667
Case 9	2%	Succeeded	\$112,554,667
Case 10	4%	Succeeded	\$96,571,333

Activity Name	Average Elapsed Duration	Average Delay Duration	Average Throughput
Notify to the supervisor or designed operator (O-11)	30 minutes	0 seconds	2 work items / hour
Put the equipment in a low position (O-3)	24 minutes 43.74 seconds	14 minutes 43.74 seconds	2.423333 work items / hour
Reason for Error Condition	0 seconds	0 seconds	Invalid value
Recheck & Complete Inspection & Verification	15 minutes	0 seconds	4 work items / hour
Remove all label and/or material from the previous ...	1 minute	0 seconds	60 work items / hour
Remove the dust from the previous lot using the va ...	15 minutes	0 seconds	4 work items / hour
Transportation of the mop to the area (T-2)	31 minutes 19.2 seconds	1 minute 19.2 seconds	1.915707 work item / hour
Transportation of the mop to the area (T-1)	33 minutes 40 seconds	3 minutes 40 seconds	1.702170 work item / hour
Use a cloth to remove the excess of dust from the ...	20 minutes	0 seconds	3 work items / hour
Use the mop to clean the floor (O-6)	15 minutes	0 seconds	4 work items / hour
Verify that the equipment is "off" (O-1)	1 minute	0 seconds	60 work items / hour
Waiting for complete the inspection (D-14)	1 minute	0 seconds	60 work items / hour

Model Driven Integration: Building for the Future

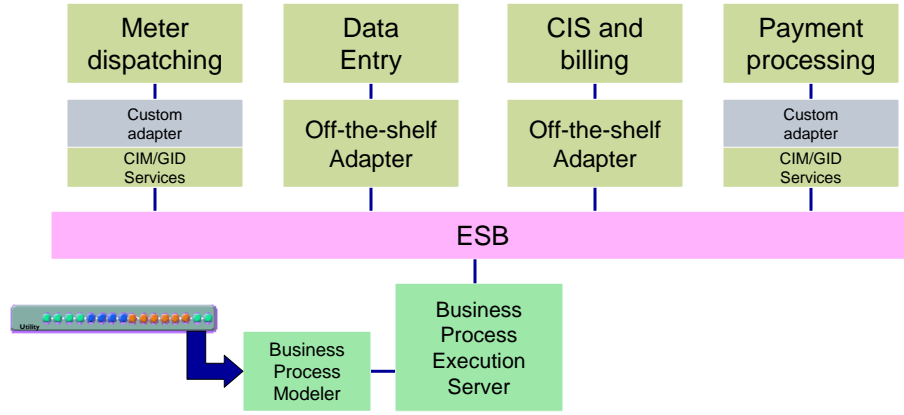

Model Driven Integration: Building for the Future

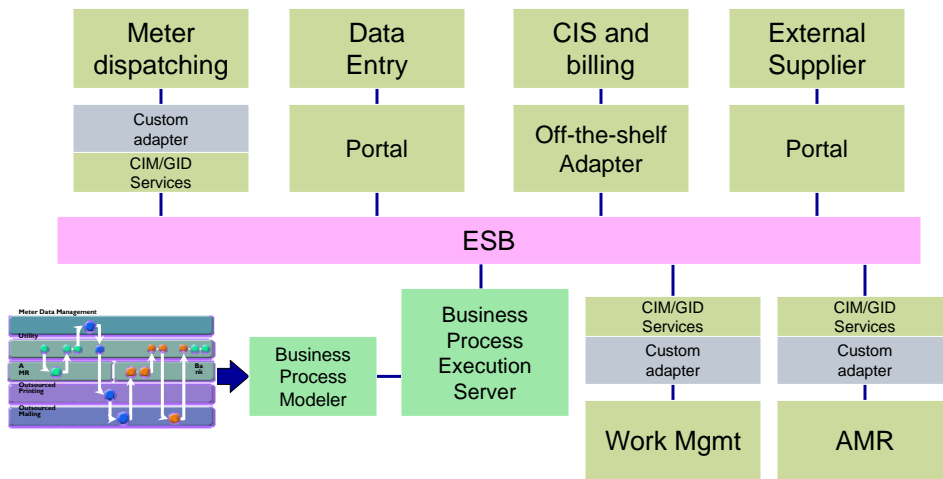

Questions - Discussion



CIMug Meeting – 10 June 2008
Västerås, Sweden
GID Tutorial

Thank You



Ralph Mackiewicz
SISCO, Inc.
6605 19½ Mile Road
Sterling Heights, MI 48314-1408 USA
Tel: +1-586-254-0020 x103
Fax: +1-586-254-0053
Email: ralph@sisonet.com